

## How Translucent Panels Are Viewed by United States Building Codes

### Light Transmitting Glazing

- UniQuad®, Pentaglas®, Quadwall®, U-Lite and Danpalon®, systems are recognized as “Approved Plastics” with CC1 Classification, for use as light transmitting materials in buildings and structures.
- UniQuad, Pentaglas, Quadwall, U-Lite and Danpalon, systems meet the three (3) requirements of the building code as an approved light transmitting panel:
  1. Self-ignition temperature of 650 degrees F or greater per ASTM 1929 (passed 1058 degrees F).
  2. Smoke density of no greater than 75 % per ASTM 2843 (passed at 54%).
  3. Burning extend of 1” or less per ASTM D635 to be classified as CC1.

### Roof Assemblies and Roof Coverings

- The special patented Quadwall Fire Rated Panel System meets the fire classification for Roof Assemblies and Roof Coverings for “Class A”, “Class B” and “Class C” (US Patent #5,437,129).
- The Quadwall Fire Rated Panel System meets the requirements for a “Class A roofing system per UL 790, ASTM E-108.
- The Quadwall Fire Rated panel system is listed and certified as “Class A” by an approved testing agency.
- “Class B” and “Class C” listings by an approved testing agency are available.

### Interior Finishes

- UniQuad, Pentaglas, Quadwall, U-Lite and Danpalon all meet a Flame-Spread Index (FSI) of 25 or less (Class A) and Smoke-Development Index (SDI) of 450 or less when tested in accordance with ASTM E-84.
- “Class B” and “Class C” FSI are available.

### Evaluation Reports

UniQuad, Pentaglas, Quadwall, U-Lite and Danpalon were evaluated by the ICC for compliance with The Building Code per the attached evaluation reports:

- ICC Legacy Report 94160A
- ICC Legacy Report ESR-1253

### Link to ICC website for current copies of CPI Evaluation Reports:

<http://www.icc-es.org/reports/index.cfm>



Most Widely Accepted and Trusted

# ICC-ES Report

## ESR-1253

ICC-ES | (800) 423-6587 | (562) 699-0543 | [www.icc-es.org](http://www.icc-es.org)

Reissued 07/2015  
This report is subject to renewal 07/2016.

DIVISION: 08 00 00—OPENINGS  
SECTION: 08 84 00—PLASTIC GLAZING

REPORT HOLDER:

**CPI DAYLIGHTING, INC.**

28662 NORTH BALLARD DRIVE  
LAKE FOREST, ILLINOIS 60045

EVALUATION SUBJECT:

**QUADWALL, UNIQUAD, PENTAGLAS, DUALWALL AND U-LITE PANELS**



A Subsidiary of



Look for the trusted marks of Conformity!

*"2014 Recipient of Prestigious Western States Seismic Policy Council (WSSPC) Award in Excellence"*

*ICC-ES Evaluation Reports are not to be construed as representing aesthetics or any other attributes not specifically addressed, nor are they to be construed as an endorsement of the subject of the report or a recommendation for its use. There is no warranty by ICC Evaluation Service, LLC, express or implied, as to any finding or other matter in this report, or as to any product covered by the report.*



**ICC-ES Evaluation Report****ESR-1253**

Reissued July 2015

*This report is subject to renewal July 2016.*[www.icc-es.org](http://www.icc-es.org) | (800) 423-6587 | (562) 699-0543

A Subsidiary of the International Code Council®

**DIVISION: 08 00 00—OPENINGS**  
**Section: 08 84 00—Plastic Glazing****REPORT HOLDER:****CPI DAYLIGHTING, INC.**  
**28662 NORTH BALLARD DRIVE**  
**LAKE FOREST, ILLINOIS 60045**  
**(847) 816-1060**  
[www.cpidaylighting.com](http://www.cpidaylighting.com)**EVALUATION SUBJECT****QUADWALL, UNIQUAD, PENTAGLAS, DUALWALL AND  
U-LITE PANELS****1.0 EVALUATION SCOPE****Compliance with the following codes:**

- 2012, 2009 and 2006 *International Building Code*® (IBC)
- 2013 *Abu Dhabi International Building Code* (ADIBC)<sup>†</sup>

<sup>†</sup>The ADIBC is based on the 2009 IBC. 2009 IBC code sections referenced in this report are the same sections in the ADIBC.**Property evaluated:**

Light-transmitting plastics

**2.0 USES**

The Quadwall, UniQuad, Pentaglas, Dualwall and U-Lite panels described in this report comply with the requirements for light-transmitting plastics in 2012, 2009 and 2006 IBC Section 2606.4. End use of the panels is outside the scope of this report, thereby requiring that compliance with the IBC requirements applicable to the end use (such as, but not limited to, structural and durability performance) be demonstrated to the code official.

**3.0 DESCRIPTION**

The Quadwall, UniQuad, Pentaglas, Dualwall and U-Lite translucent polycarbonate panels recognized in this report are light-transmitting plastics complying with IBC Section 2606.4, and have a CC1 plastic combustibility classification. The panels are available in up to a 45.3-foot (13 800 mm) length and in various widths, thicknesses and configurations. See Table 1 and Figure

1 for size and configuration details. As shown in Table 1 and Figure 1, the 8- and 10-millimeter-thick Quadwall, UniQuad, and Pentaglas panels are identical panels, except for the product name.

**4.0 INSTALLATION**

Use of the Quadwall, UniQuad, Pentaglas, Dualwall and U-Lite panels recognized in this report is limited to applications permitted by the IBC for light-transmitting plastics. The manufacturer's published installation instructions and this report must be strictly adhered to.

**5.0 CONDITIONS OF USE**

The Quadwall, UniQuad, Pentaglas, Dualwall and U-Lite panels described in this report comply with, or are suitable alternatives to what is specified in, those codes indicated in Section 1.0 of this report, subject to the following conditions:

- 5.1** The panels are manufactured, installed and identified as called for in this report, the IBC and the manufacturer's published installation instructions. In the event of a conflict between this report and the manufacturer's published installation instructions, this report governs.
- 5.2** End use of the panels requires justification of compliance with appropriate code requirements, including installation, structural, impact and durability considerations.

**6.0 EVIDENCE SUBMITTED**

- 6.1** Reports of tests in accordance with ASTM D1929, ASTM D2843, ASTM D635, and ASTM E84.
- 6.2** Quality documentation.

**7.0 IDENTIFICATION**

The panels are identified with a label bearing the manufacturer's name (CPI Daylighting), the product name (Quadwall, UniQuad, Pentaglas, Dualwall or U-Lite), the CC1 plastic classification and the evaluation report number (ESR-1253).

TABLE 1—PANEL DESCRIPTIONS<sup>1</sup>

PANEL TYPE	PANEL THICKNESS	CORE CONFIGURATION	PANEL WIDTH
Quadwall UniQuad Pentaglas	8 mm	Square (Multi-cell)	600 mm
		Honeycomb	600 mm
	10 mm	Square (Multi-cell)	600 mm
		Honeycomb	600 mm
Pentaglas	12 mm	Square (Multi-cell)	600 mm
		Honeycomb	900 mm
	16 mm	Square (Multi-cell)	600 mm
			900 mm
		Honeycomb	600 mm
			1040 mm
Dualwall	8 mm	Square	600 mm
	10 mm	Square	600 mm
U-Lite	4 mm	n/a	600 mm

For SI: 1 inch = 25.4 mm, 1 pound per linear foot = 1.48 kg/m.

<sup>1</sup>See Figure 1 for panel configuration details

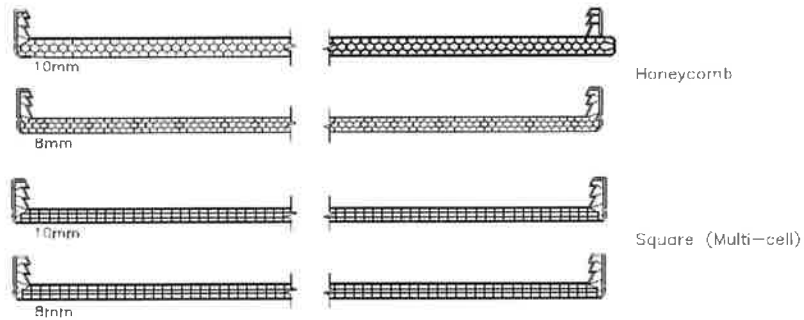

Quadwall, UniQuad, and Pentaglas 8mm and 10mm Panel Profiles

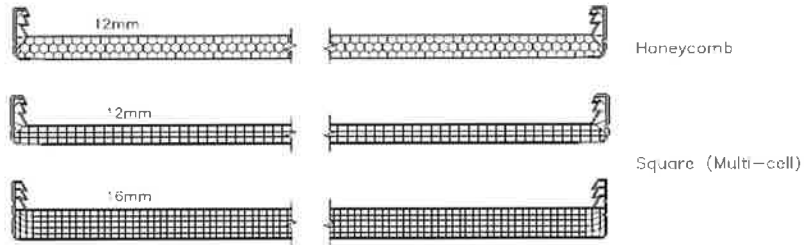

Pentaglas 12mm and 16mm Panel Profiles

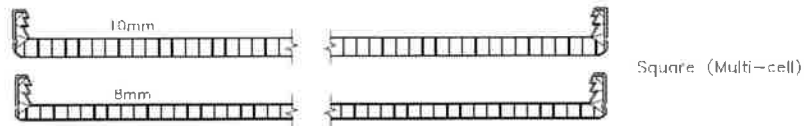

Dualwall 8mm and 10mm Panel Profiles



U-Lite 4mm Panel Profiles

FIGURE 1—PANEL PROFILES



# LEGACY REPORT

CPI # 110  
ICC Legacy Report for All Danpalon Systems  
and Quadwall Class A System **94160A**

Reissued November 1, 2001

**ICC Evaluation Service, Inc.**  
[www.icc-es.org](http://www.icc-es.org)

**Business/Regional Office** ■ 5360 Workman Mill Road, Whittier, California 90601 ■ (562) 699-0543  
**Regional Office** ■ 900 Montclair Road, Suite A, Birmingham, Alabama 35213 ■ (205) 599-9800  
**Regional Office** ■ 4051 West Flossmoor Road, Country Club Hills, Illinois 60478 ■ (708) 799-2305

The Committee on Evaluation has reviewed the data submitted for compliance with the *Standard Building Code* and submits to the Building Official or other authority having jurisdiction the following report. The Committee on Evaluation, SBCCI PST & ESI and its staff are not responsible for any errors or omissions to any documents, calculations, drawings, specifications, tests or summaries prepared and submitted by the design professional or preparer of record that are listed in the Substantiating Data Section of this report. Portions of this report were previously included in Evaluation Reports #9373 and #94160.  
Copyrighted © 1999 SBCCI PST & ESI

REPORT NO.: 94160A

EXPIRES: See the current EVALUATION REPORT INDEX

CATEGORY: GLAZING

SUBMITTED BY:

CPI INTERNATIONAL, INC.  
28662 N. BALLARD DRIVE  
LAKE FOREST, ILLINOIS 60045

## 1. PRODUCT TRADE NAME

Danpalon® F.R. Panel Types:

- 1.1 Quadwall® Class A Roof Material
- 1.2 Quadwall®
- 1.3 Dualwall™
- 1.4 Pentawall™

## 2. SCOPE OF EVALUATION

- 2.1 Danpalon® F.R. Panels - approved light transmitting plastic
- 2.2 Quadwall™ Class A Roof Panels - Class A Roof Covering Rating, and interior finish classification

## 3. USES

CPI International's Danpalon® F.R.-Dualwall™, Pentawall™, and Danpalon® F.R.-Quadwall® panels together with joining and mounting accessories are intended for use as light-transmitting closures for openings in exterior walls and in roofs.

## 4. DESCRIPTION

### 4.1 Danpalon® F.R.

Danpalon® F.R. is the coextruded polycarbonate glazing panel which forms the basis of all the assemblies manufactured by CPI.

Danpalon® F.R. plastic panels were tested in accordance with ASTM D 1929 Ignition Properties of Plastics, ASTM D 2843 Standard Test Method for Density of Smoke From the Burning or Decomposition of Plastics, and ASTM D 635 Rate of Burning and/or Extent and Time of Burning of Self-Supporting Plastics in a Horizontal Position. The Danpalon® F.R. plastic face sheet material exhibits characteristics which allow it to be classified as an approved plastic type CC-1.

The Class A roof covering assemblies noted in Items 4.3.3 have been tested in accordance with ASTM E 108 Fire Tests of Roof Coverings to be qualified as Class A roof covering. When tested according to ASTM E 84 Surface Burning Characteristics, Danpalon® F.R. exhibited an interior flame spread of less than 25 and a smoke density of less than 450. This qualifies the material as a Class A interior finish.

Danpalon® F.R. panels were tested in 10 mm (0.40 inch) thickness for elevated temperature failure. Each panel was 28 inches (711 mm) wide and 12 inches (305 mm) long, and contained two 12 inch (305 mm) long edge joints. Both the quad (with H-channel locking connections) and dual glazed configuration (with U-channel locking connections) were tested to a temperature of 300° F (150° C) for 25 minutes.

A 10 psf (479 pa) dead load was added and the loaded panel was maintained at 300° F (150° C) for an additional 25 minutes. In both tests the sample joints remained intact and the panels did not sag or dislodge.

### 4.2 Panel Types - General

All systems are covered with the Danpalon® F.R. plastic face sheet material. Four systems are fabricated; the Dualwall, the Pentawall, the Quadwall, and Quadwall Class A panels. The Danpalon® F.R. system consists of (a) main panels extruded with standing seam, 5/8" (16 mm) upstands protruding 90 degrees to the panel face; (b) a variety of snap-on and interlocking profiles made from polycarbonate or aluminum; (c) stainless steel retention clips; (d) structural supporting systems (not covered in report); and (e) a variety of perimeter aluminum profiles. See Figure No. 1.

ICC-ES legacy reports are not to be construed as representing aesthetics or any other attributes not specifically addressed, nor are they to be construed as an endorsement of the subject of the report or a recommendation for its use. There is no warranty by ICC Evaluation Service, Inc., express or implied, as to any finding or other matter in this report, or as to any product covered by the report.

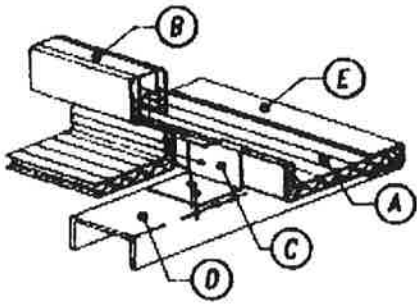

FIGURE NO. 1

The fully assembled system is free floating to allow for thermal expansion and contraction.

4.3 Panel Types - Specific

4.3.1 Dualwall and Pentawall

The Dualwall and Pentawall panels are a single layer assembled from Danpalon® F.R. sheets with the "formed in" vertical legs face up and a "U" clip attaching each pair of panels. See Figures No. 2 and No. 3.

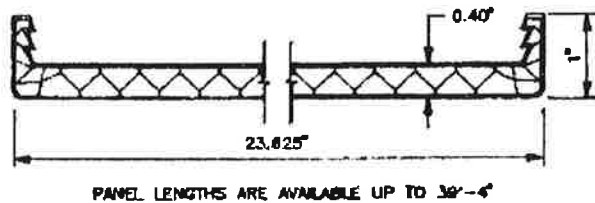

PANEL LENGTHS ARE AVAILABLE UP TO 39'-6"

FIGURE NO. 2  
Dualwall

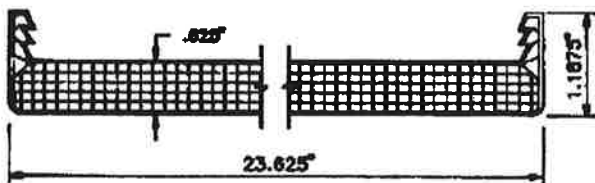

PANEL LENGTHS ARE AVAILABLE UP TO 39'-4"

FIGURE NO. 3  
Pentawall

4.3.2 Quadwall

The Quadwall panel is assembled from Danpalon® F.R. sheets with the "formed in" vertical legs face up on the inside sheets and face down on the outside sheets, and a "H" clip attaching the four panels. See Figure No 4.

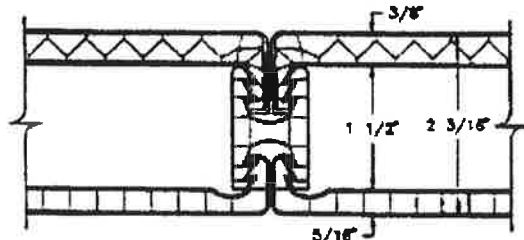

STANDARD EXTRUDED POLYCARBONATE  
"H" BATTEN DETAIL

FIGURE NO. 4  
Quadwall

4.3.3 Quadwall Class "A" Roof Covering

The Quadwall Class "A" Roof Covering Panel is similar on the surface to the Quadwall panel described in Item 4.3.2 above, in that the outside panels are Danpalon® F.R. Inside the panel are structural modifications which allow the special assembly to satisfy the requirements of a Class A roof by ASTM E-108. This special panel is fabricated as follows (patent pending):

The perimeter aluminum frame is constructed with mitered and welded corners. EPDM gasket material is inserted into the lower horizontal leg of the frame and the plastic panels are laid into the frame with the "formed-in" vertical legs face up. The center aluminum "H" channel is then snapped onto the meeting edge legs of the bottom plastic panels. The stainless steel screen is then laid on top of the bottom panels and secured to the center aluminum H-channel with self drilling screws at approximately 1 foot (305 mm) intervals. The outside perimeter of the screen and plastic panel are then secured by snap in channels which lock into the frame. I-beams spaced 12 inches (305 mm) on center are also inserted and held in place by notches in the H-channels extrusion at the center and placed between the snap-in channels at the edges. The insulation is then placed in the cavities formed between the I-beam, and the top plastic panels are installed by snapping downward legs at the meeting edge into the top of the H-channel. Finally, the perimeter edge of the top panels is secured by screwing down the glazing stop with self tapping bolts. The top glazing stop includes an EPDM gasket placed in a groove in the extrusion. See Figure No. 5.

This specially constructed panel obtained a Class A rating by tests according to ASTM E 108, including burning brand, intermittent flame, and spread of flame tests.

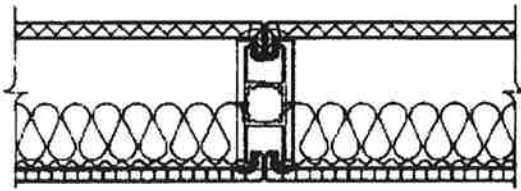

FIGURE NO. 5

## 5. INSTALLATION

The manufacturer's published detailed installation instructions shall be strictly adhered to and shall be incorporated into the working drawings which shall be available at all times on the job site during installation.

## 6. SUBSTANTIATING DATA

- 6.1 Manufacturer's descriptive literature.
- 6.2 Test report for ASTM D 1929 by United States Testing Company; Reference 182488; dated June 29, 1990; signed by G. Banasky and M. S. Elliott.
- 6.3 ASTM D 2843 Test Report by United States Testing Company, Inc.; Test Report #185283; dated January 21, 1991; signed by Y. L. Yeung and M. S. Elliott.
- 6.4 ASTM E 84 Test Report by United States Testing Company, Inc.; Test Report Number 185585-2; dated July 12, 1991; signed by G. Banasky, Y. L. Yeung, and M. S. Elliott
- 6.5 Test report on Smoke Density of Plastic Material in accordance with ASTM D 2843, prepared by United States Testing Company, Inc., Report No. 188107-1, dated December 29, 1993, signed by Yuk Lun Yueng and Michael S. Elliott.
- 6.6 ASTM C 236 at 15 mph wind speed on Dualwall, by WHI; Test Report #633-90851; dated March 10, 1989; signed by J. McFee and R. Curkeet, P.E.
- 6.7 Test report for ASTM D 635 by Warnock Hersey; WHI Test Report #631-009400; dated April 3, 1990; signed by E. Hodgson and R. Curkeet, P.E.
- 6.8 ASTM E 331 at 15 spf on Dualpanel by WHI; Test Report #633-200301; dated January 8, 1992; signed by R. Burt and R. Curkeet, P.E.
- 6.9 ASTM E 331 at 15 psf on Quad Panel System by WHI; Test Report #633-200302; dated January 8, 1992; signed by R. Burt and R. Curkeet, P.E.
- 6.10 ASTM E 283 at 15 psf on Dualwall panel configuration by WHI, Test Report #633-200303, dated January 8, 1992; signed by R. Burt and R. Curkeet, P.E.
- 6.11 ASTM E 108 Test Report by Warnock Hersey; Report Number WHI-495-R-0702; dated March 10-12, 1992; signed by T. Woodbeck and G. E. Meyer, P.E.
- 6.12 Shatter Resistance of Flat Panels by ASTM D 3841-80/SPI Method B on 10 mm Danpalon F.R.; by WHI; dated September 10, 1992; Report #633-215703; signed by W. Keen and R. Curkeet, P.E.
- 6.13 Elevated temperature loading tests by WHI, Test Report #633-300501, dated February 3, 1993, signed by R. Curkeet, P.E.
- 6.14 ASTM E 330-90 Test Report by Warnock Hersey Inc. on Class A roof panels; Test Report #633-300502; dated February 11-22, 1993; signed by E. Hodgson and R. Curkeet, P.E.
- 6.15 Test report on Burning of Self Supporting Plastics in a Horizontal Position in accordance with ASTM D 635-88, prepared by Warnock Hersey, Inc., Report No. 631-327900, dated January 13, 1994, signed by Edwin Hodgson and Rick Curkeet, P.E.
- 6.16 Danpalon Gravity Load Tests by Pittsburg Testing Laboratory; dated June 20, 1985; Report No. 01; signed by D. R. Scott.
- 6.17 Loading test by PSI Jammal & Associates, Inc.; dated July 11, 1990; signed by J. R. Manquandt, P.E.

## 7. CODE REFERENCES

*Standard Building Code* - 1994 Edition

Section 103.7	Alternate Materials and Methods
Section 202	Definitions - Plastic, Approved
Section 1509.2	Fire Resistance Classification
Section 2407	Sloped Glazing
Section 2604	Light-Transmitting Plastics
Section 3108.5	Use of Plastic Materials - Signs

## 8. COMMITTEE FINDINGS

The Committee on Evaluation in review of the data submitted finds that, in their opinion, the CPI panels as described in this report conform with or are suitable alternates to that specified in the *Standard Building Code* or Supplements thereto.

## 9. LIMITATIONS

- 9.1 This Evaluation Report and the installation instructions, when required by the Building Official, shall be submitted at the time of permit application.
- 9.2 The scope of this report does not include an evaluation of structural performance maximum span or roof loading. Engineering/Calculations or test reports must be submitted to the Building Official showing that the assembled Quadwall Class A roof panels will resist the design loads from Chapter 16 of the *Standard Building Code*.
- 9.3 Since the Quadwall Class A Panel, when assembled as described in Item 4.3.3 has attained a Class A roof classification, then such panels are exempt from the limitations of Section 2604.5 relating to separation of roof panels and maximum area of individual panels and from the similar limitations of Section 2604.6 relating to skylights.
- 9.4 The face of Quadwall Class A roof panels which are exposed to the interior of the building shall exhibit the flame spread classifications required in Section 803 and Table 803.3.
- 9.5 None of the Danpalon® F.R. systems have been tested or evaluated by ASTM E 119 to obtain an hourly rating.
- 9.6 CPI panel assemblies other than those shown in Item 4.3.3 may be used subject to the limitations of Section 2604.

**10. IDENTIFICATION**

All packages of CPI's Danpalon® F.R.-DUALWALL™, Pentawall™, and Danpalon® F.R.-QUADWALL® listed in this report shall bear the manufacturer's name and/or trademark, the type of material, the SBCCI Public Safety Testing and Evaluation Services Inc. Seal or initials (SBCCI PST & ESI), and the number of this report for field identification.

Each panel of Danpalon® F.R.-QUADWALL® CLASS A ROOF MATERIAL manufactured in accordance with Item 4.3.3 shall bear identification as a Class A roof covering, the Warnock Hersey Identification, and the package shall bear the SBCCI Public Safety Testing and Evaluation Services Inc. Seal or initials (SBCCI PST & ESI), and the number of this report for field identification.

**11. PERIOD OF ISSUANCE**

SEE THE CURRENT EVALUATION REPORT INDEX FOR STATUS OF THIS EVALUATION REPORT.

For information on this report contact:  
Woods McRoy, P.E.  
205/599-9800